



TECAST VEKTON™

(Cast nylon sheaves)

TECAST VEKTON Cast Nylon Sheaves offer a longer lasting, corrosion and abrasion resistant, cost effective alternative to steel sheaves. As demonstrated by actual field service experience, TECAST VEKTON sheaves significantly outlast the steel sheaves they replace, and wire rope life is typically increased two to three times. TECAST VEKTON sheaves are 1/7th the weight of their steel counterparts, substantially reducing the weight of the boom tip. This increases the lifting capacity and stability of the crane, making handling during installation much easier and safer, and decreases "over-the-road" weight on the axles.

TECAST VEKTON sheaves combine excellent "built-in" lubricity with high impact resistance and cost less than steel sheaves because minimal machining is needed to accommodate bearings. In addition, since the wire rope service life is increased and lubrication is not required after the initial application, maintenance costs are dramatically reduced. All TECAST VEKTON sheaves can be supplied with roller bearings, bronze sleeves, or with a plain bore. Grease fittings and lubrication passages can be added, as needed.



11-1/2", 15-3/8", and 22" OD sheaves are shown above.

- **Longer Life—**

TECAST VEKTON significantly outlasts steel sheaves and typically increase wire rope life 2 to 3 times.

- **Outstanding Physical Properties—**

TECAST VEKTON combines excellent "built-in" lubricity with high impact, corrosion, and abrasion resistance.

- **Weight Reduction—**

TECAST VEKTON is 1/7th the weight of steel sheaves, substantially reducing weight of the boom tip and increasing a crane's lifting capacity and stability.

- **Low Cost—**

TECAST VEKTON has a lower initial cost than steel and a dramatically reduced maintenance cost.

TECAST VEKTON 6PA and 6PAM sheaves are currently operating in crane applications in the construction and marine industries. TECAST VEKTON Cast Nylon Sheaves are available in a variety of standard sizes (see back side). We welcome the opportunity to supply other sizes. Contact your Ensinger representative.

TECAST VEKTON™ STANDARD CAST SHEAVES

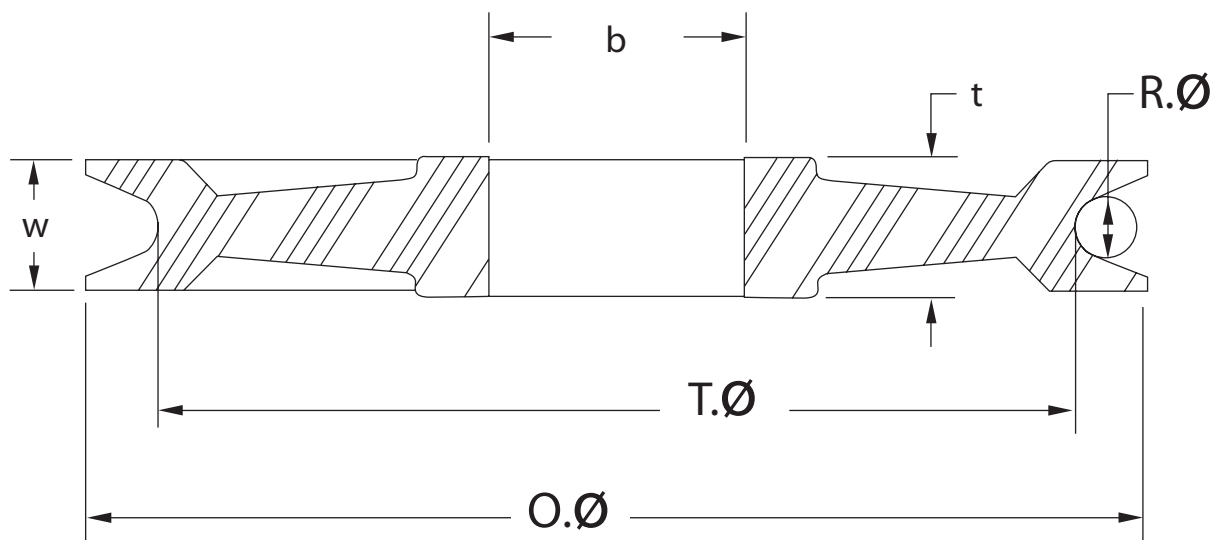

Outside Dia. (O.Ø)	Tread Dia. (T. Ø)	Rope Dia. (R. Ø)	Max. Bore (b)	Bore Width (t)	Rim Width (w)
11-1/2"	9-9/16"	9/16"	5-1/4"	1-3/4"	1-5/8"
13-1/4"	11-1/2"	3/4"	4"	1-3/4"	1-5/8"
15-3/8"	12-3/4"	9/16"	5"	1-3/4"	1-5/8"
14-1/8"	11-5/8"	1/4"	4"	4-13/16"	4-13/16"
13-7/8"	11-5/8"	5/8"	5-1/4"	2-1/2"	1-3/4"
13-7/8"	11-5/8"	3/4"	5-1/4"	2-1/2"	1-3/4"
15-3/8"	15-3/8"	3/4"	5-3/4"	2-1/2"	2-1/2"
18-1/2"	N/A	N/A	2-3/4"	2-3/8"	1-9/16"
22"	N/A	N/A	6"	2-1/2"	2-1/2"

Several sizes of machined sheaves are available up to 50" O.D.
Please call with your size requirements.



Division of Ensinger, Inc.

1 Main Street
Grenloch, New Jersey 08032
Telephone: 800.243.3221
856.227.0500
FAX: 856.232.1754

HEADQUARTERS
365 Meadowlands Boulevard
Washington, Pennsylvania 15301
Telephone: 724.746.6050
FAX: 724.746.9209

E-mail: sales@ensinger-ind.com

Web site: www.shopforplastics.com